

REVISION TABLE					
REV	ECN	DESCRIPTION	REV BY	APPROVED	DATE
---	---	Original Drawing	OGG	MPW	9-9-2020

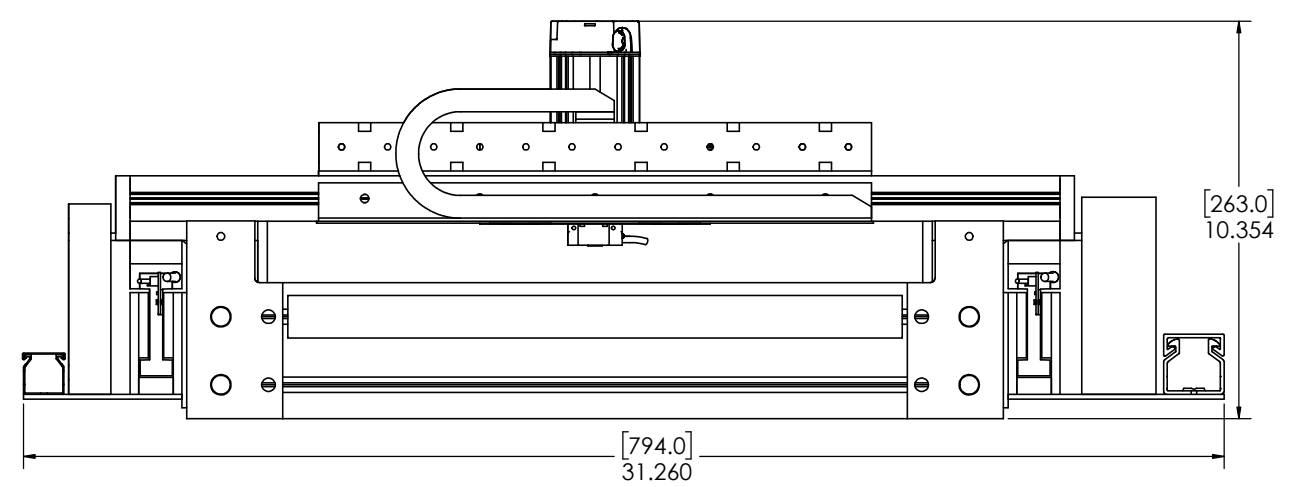

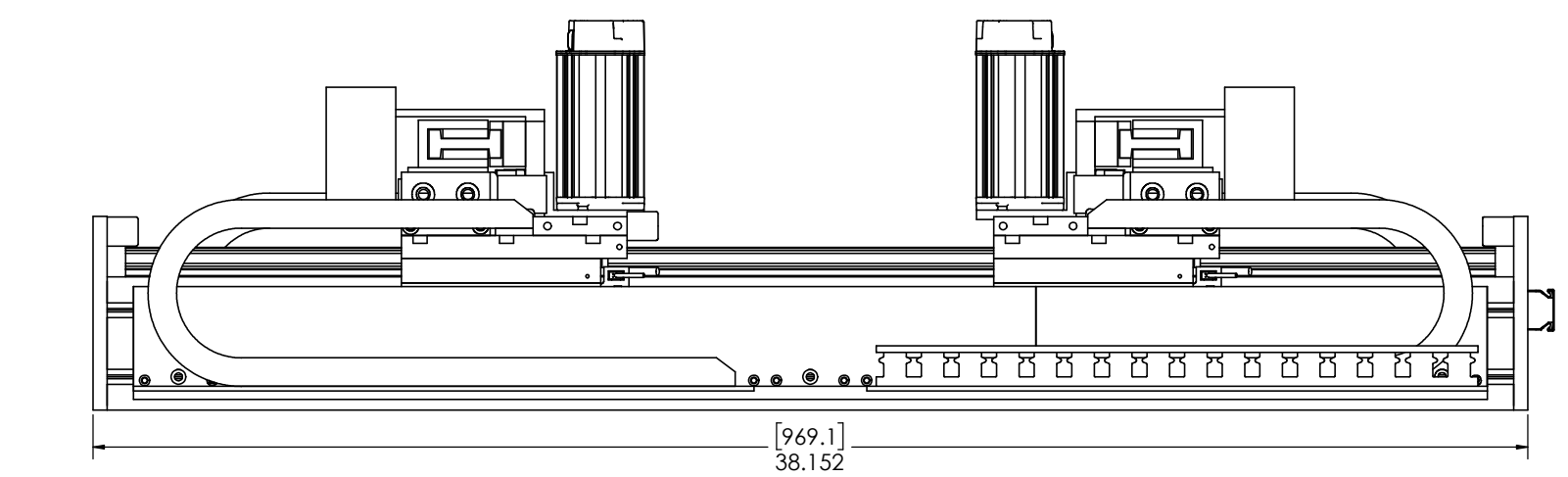
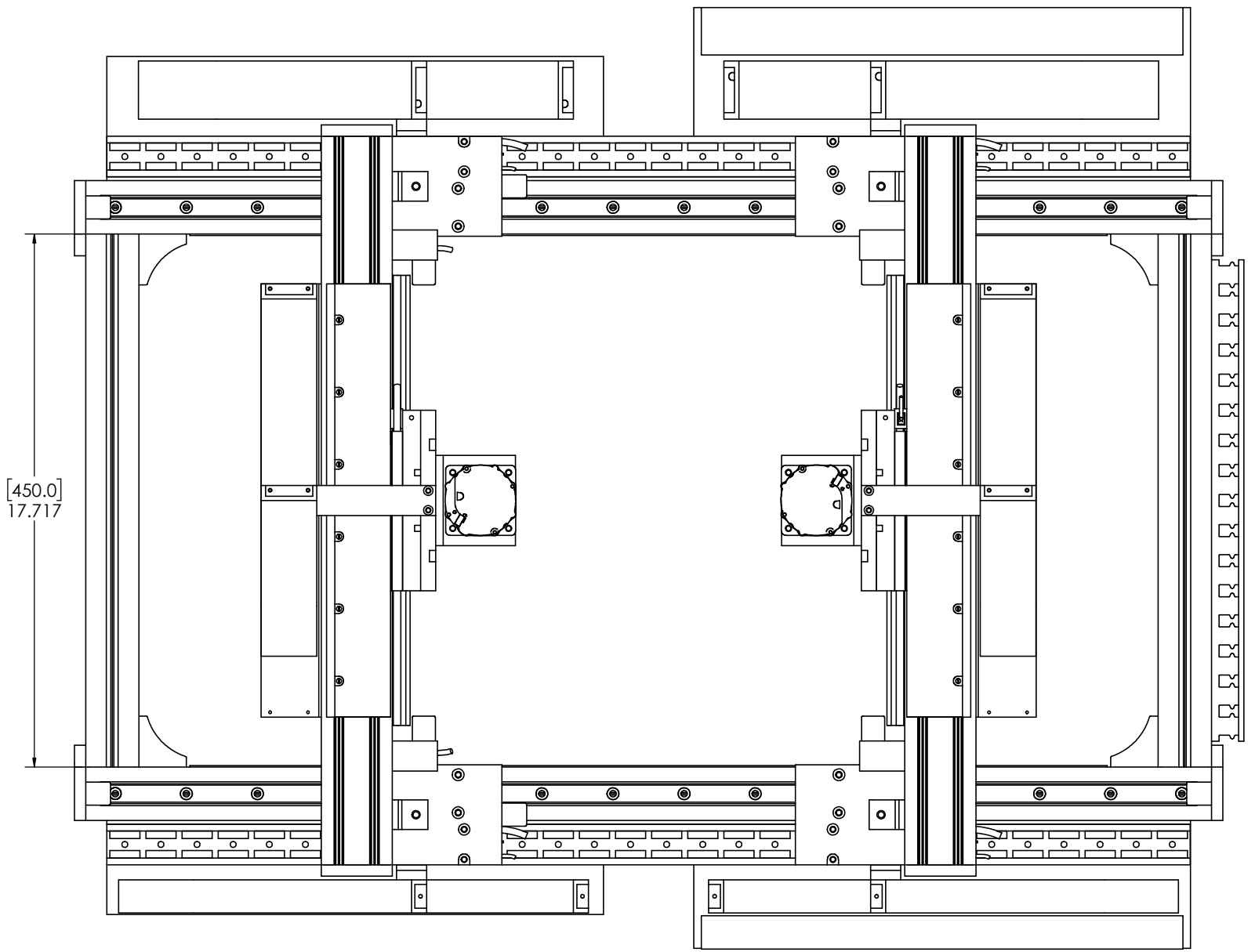
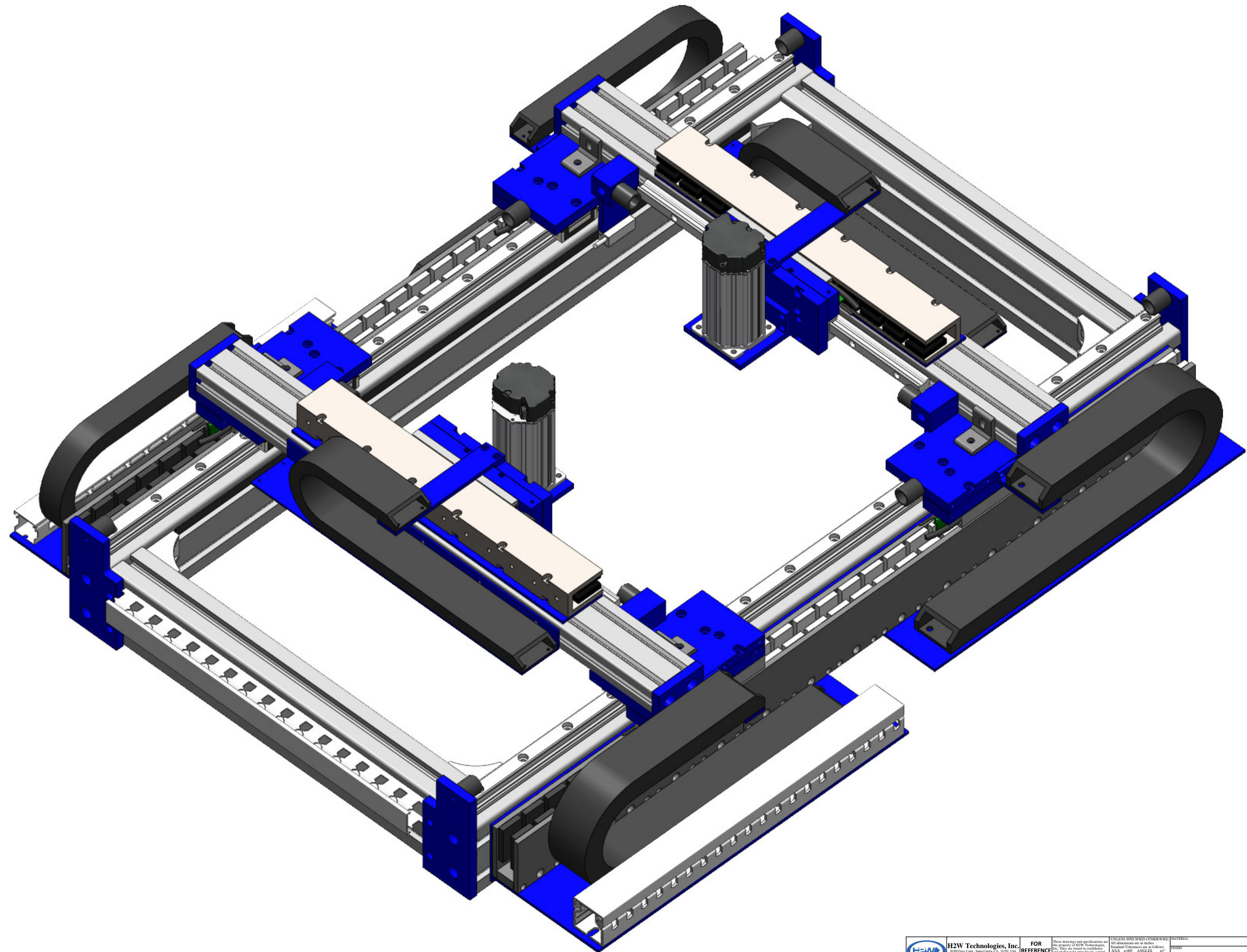

SYSTEM SPECIFICATIONS

Bottom Axis (Parallel Single Rail Stages)*		
Motor P/N	BLDM-D04	
Stroke (MAX)	22.9 in	582 mm
Encoder Resolution	1 micron	
Bearing Type	Recirculating Ball	
Resistance @ 20C	18.2 ohms	
Inductance @ 20C	24.2 mH	
Electrical Time Constant	1.3 msec	
Motor Constant	2.6 LBS/SQRT(Watt)	11.6 N/SQRT(Watt)
Force Constant	11.2 LBS/Amp	49.6 N/Amp
Back EMF	1.3 V/ips	49.6 V/m/sec
Force @ 100% Duty	16.5 lbs	73.6 N
Power @ 100% Duty	51.8 watts	
Current @ 100% Duty	1.5 amps	
Force @ 10% Duty	49.0 lbs	220 N
Power @ 10% Duty	466 watts	
Current @ 10% Duty	4.4 amps	

Top Cross Axis		
Motor P/N	BLDM-C04	
Stroke	8.25 in	210 mm
Encoder Resolution	1 micron	
Bearing Type	Recirculating Ball	
Resistance @ 20C	10.6 ohms	
Inductance @ 20C	10.1 mH	
Electrical Time Constant	1.0 msec	
Motor Constant	2.1 LBS/SQRT(Watt)	9.4 N/SQRT(Watt)
Force Constant	6.8 LBS/Amp	30.5 N/Amp
Back EMF	0.77 V/ips	30.4 V/m/sec
Force @ 100% Duty	13.0 lbs	58.0 N
Power @ 100% Duty	49.5 watts	
Current @ 100% Duty	1.9 amps	
Force @ 10% Duty	39.0 lbs	173 N
Power @ 10% Duty	445 watts	
Current @ 10% Duty	5.7 amps	

* Motor specifications are per each individual motor

Rotary Axis	
Motor P/N	M-2341S-LN-02D
Encoder Resolution	2000 cnts/rev
Resistance @ 20C	2.98 ohms
Inductance @ 20C	4.59 mH
Electrical Time Constant	1.54 msec
Force Constant	14.1 oz-in/Amp
Back EMF	35.35 Vpeak/kRPM
Torque @ 100% Duty	183 oz-in
Power @ 100% Duty	58 watts
Current @ 100% Duty	4.42 amps
Torque @ 10% Duty	414 oz-in
Power @ 10% Duty	298 watts
Current @ 10% Duty	10.0 amps

NOTES:

- Bottom horizontal axis consists of two single rail stages connect together by a cross axis (H-Gantry)
- Bottom horizontal axis Stroke (MAX) is when one moving H-Assembly is all the way to one side.
- System total mass is 125 Lbs [57 Kg](approx.)